

Robin Masters *Band*

Bühnen- und Belegungsplan

(Stand 10.2010)

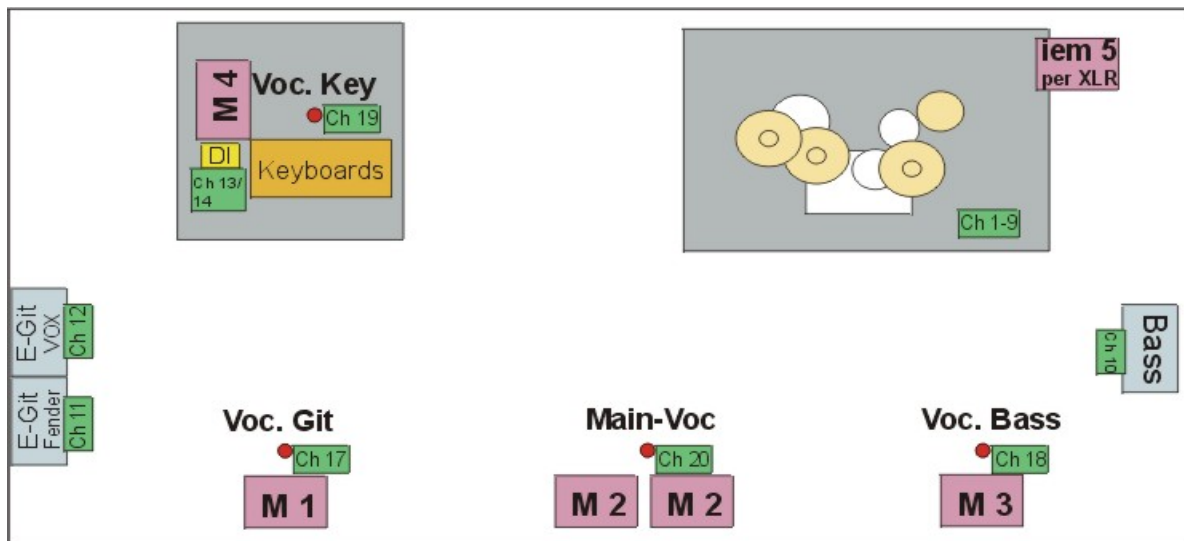

Drumriser: 3m x 2m
Keyboard-Riser: 2m x 2m

ch.	FoH Belegung	Mikrofonierung
1	Kick	Shure Beta 91, Sennheiser e901
2	Kick	Shure Beta 52, Sennheiser e902
3	Snare	Sennheiser e905, SM 57
4	Hi Hat	Sennheiser e914, AKG 391
5	Tom 1	Sennheiser e904, e604
6	Tom 2	Sennheiser e904, e604
7	Tom 3	Sennheiser e904, e604
8	OH	Sennheiser e914, c391
9	OH	Sennheiser e914, c391
10	Bass-Gitarre	D.I. Box
11	E-Git (Fender)	Sennheiser e906, SM57
12	E-Git (Vox AC30)	SM57, Sennheiser e906
13	Keyboard L	D.I.
14	Keyboard R	D.I.
15		
16		
17	Voc. Git	Shure Beta 58, SM 58, Sennheiser e935
18	Voc. Bass	Shure Beta 58, SM 58, Sennheiser e935
19	Voc. Key	eigenes Headset
20	Main-Vocals	Wireless Beta58 / SM58
21	Main-Vocals	Y-Adapter von ch. 20 (nur bei Monitormix vom FoH)
22	CD / iPod	
23	CD / iPod	
24	Talkback	irgendein dynamisches Mic, möglichst mit Schalter